



Pountney Street, Wolverhampton, WV2 4HX ☎ 01902 450550
email:sales@thebathingplace.com www.thebathingplace.com

Step by Step assembly instructions for Domestic Sauna Cabin

General.

Before you begin please take the time to read through these instructions.

Before you begin the assembly work recommended you read through these instructions slowly and completely in order to familiarise yourself with the procedure.

Saunas can be erected onto the existing floor that can be vinyl, ceramic, concrete but not carpet or wood.

You will require the following items:- A powered drill/screw driver with drill bits and posi screw driver and countersink tool, spirit level, hammer and a saw.

Step 1.

Join panels together to form corners of the cabin. (Note panels forming the side walls are to be drilled using 5mm dia drill). Fix together using 4 x 85mm x 4.8mm screws (p1). Ensure rebate is at same end on both panels. This end is the base. Note position of vent panel indicated on plan. (The lower of the two vent holes faces into cabin).

Step 2 Check that the base is level.



Step 3.

Place corner panels onto base and secure panel to base by pinning through rebate into base section. Use 25mm pins. (One at end of each panel).



(P3)



(P3)

Step 4.

Complete wall assembly with intermediate panels, using 19 x 19 corner mould screwed to the top of the panels (use 4mm dia drill and 40 x 4mm screws) Pin panel to base using 25mm pins (as in 3 above).



(P4)

Step 5.

Fitting Door frame; remove glass and hinges from door frame and store door safely.

Note when handling toughened glass, safety goggles should be worn.

Decide which side the door is to be hinges and rotate frame to suit. Ensure the glass door opens outwards, fix door frame in place using 3 x 4 x 50mm screws to each side, ensure the outside of door frame is located flush to outside face of frame.

There will be a small gap below the glass door to as an inlet for fresh air to enter the cabin when in use; according to the arrangement of the Either the top or bottom of the door frame will have a timber section to form a rebate (i.e. 9mm x 60mm x 5.50) pinned loosely in place, remove this and place aside. Position 9mm x 60 x 550 section to head of door frame and fix using 25mm pins leaving rebate door equal to side rebate.



(P5)

Step 6.

Fitting the roof; first check diagonal measurement at base to ensure cabin is square i.e. Diagonals will be equal. Locate roof panel flush to side and front edge. Screw up through 19 x 19 corner mould (previously fixed at step 4) firstly drill a 4mm dia hole and fix using 4 x 40 screws ó approx 300mm intervals. Repeat for all roof panels.



(P6)



(P6)

Step 7.

Fit bench supports; all timbers fixed to cabin walls with 6 x 4 x 40 screws pre drill timbers 3.5 mm, ensure fixing screws pick up main framework in panels (if in doubt add additional support beneath rail). **The strength of these fixings is critical as the weight of the user is carried by such.**

These dimensions will give finished bench heights of 800mm high bench, 500mm low bench.



(P7) 780mm 480mm

Step 8.

Fit heater mounting timbers; fix using 2 x 4 x 60 screws at the end of each rail ó drill holes 3.5mm dia in each end of the rail.

Ensure fixing screws enter main frame of panels by aligning screws to line of nails securing cladding ô see heater mounting instructions for all relevant clearances.

The strength of these fixings is critical to carry the weight of the heater and rocks.



(P8)

Step 9.

Internal trims; affix internal base trim (Item 10) around cabin, fix using 25mm pins located approx. 20mm from floor. Under door frame fix a small piece of scrap trim (9 x 32) with 25mm pins ó to act as a packer to support main base trim.

Where the door frame abuts a panel (see step 5a) screw a piece of corner mould (item 5 19 x 19) to the door frame and also to the adjoining panel ó (4 screws to each face 4mm x 40mm screws ó pre drill a 4mm dia). Cover this joint with 32 x 9 trim i.e.

Corner trims (item 9) ó fix in place using 25mm pins.

Cover all internal panel joints using trim (Item 10) but screw into place using 32 x 3.5mm. Screw either side of joint starting 50mm from one end and then every 300mm. This frequency will pull panels flush and will prevent further movement. (Note outer trims need only be pinned).

Where the door frame abuts the side wall ó cover 9mm slot with 32 x 9 trim ó pinned in place with 25mm pins.

Vent trim, item 8, Fix as detailed in the pack.

Step 10. Bench Assembly

Important Safety Information.

The benches may have to support the body weight of several bathers. It is important that they are correctly assembled; the holes for all screws must be predrilled to prevent the timber splitting. To tighten the screws use a hand held screwdriver or an electrically operated one with a torque setting that allows the screw to be fully tightened but not to spin as spinning reduces the holding power of the screw.

Note the use of a good quality PVA adhesive (not supplied) will improve the durability of the benches.

Maximum loadings;

Up to 1200 mm no centre support 2 x 12.5 stone people

Up to 1800 mm with 1 extra support 3 x 12.5 stones people

Up to 2400 mm with 2 extra supports 4 x 12.5 stone people

Check benches periodically to look for signs of weakening (once a year in domestic use twice a year for commercial use)

slats are 69 mm, spaces are 19 mm, width of 5 slat bench is 425 mm all dimensions +/- 1 mm

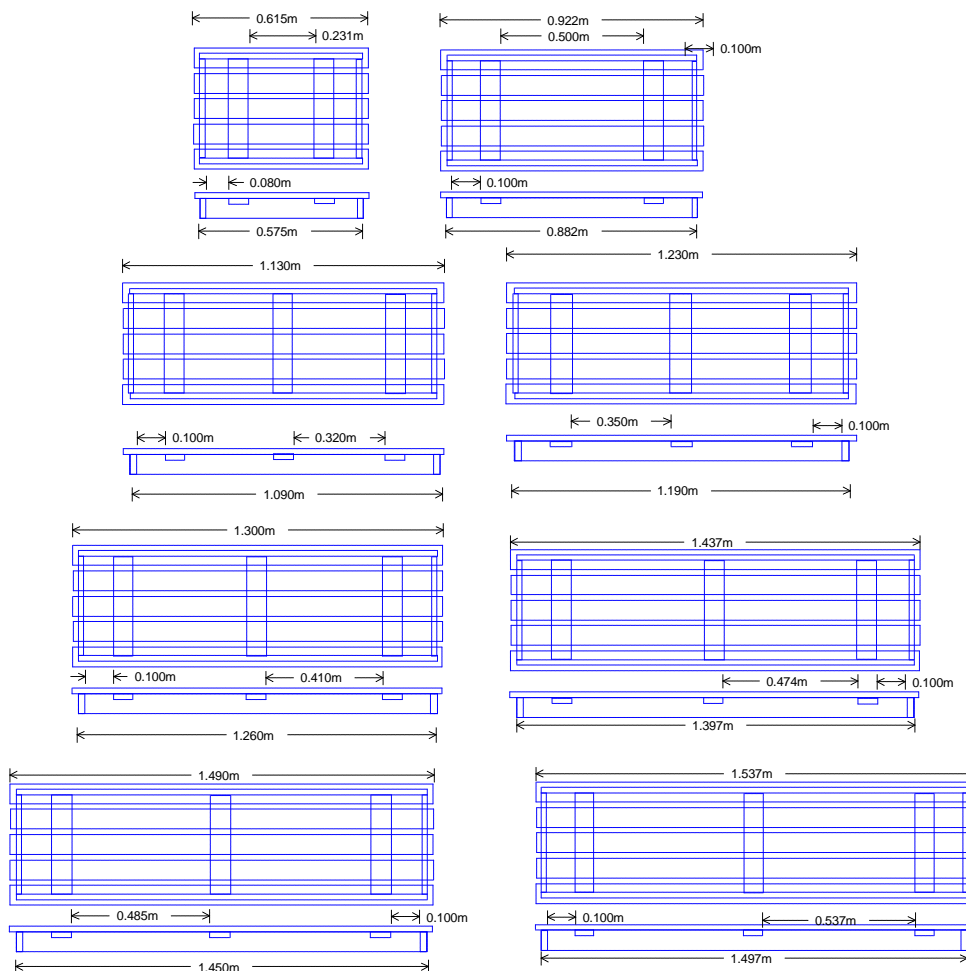

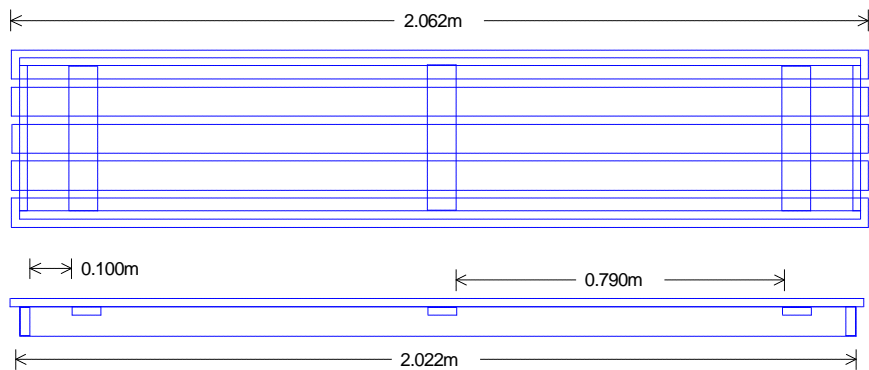
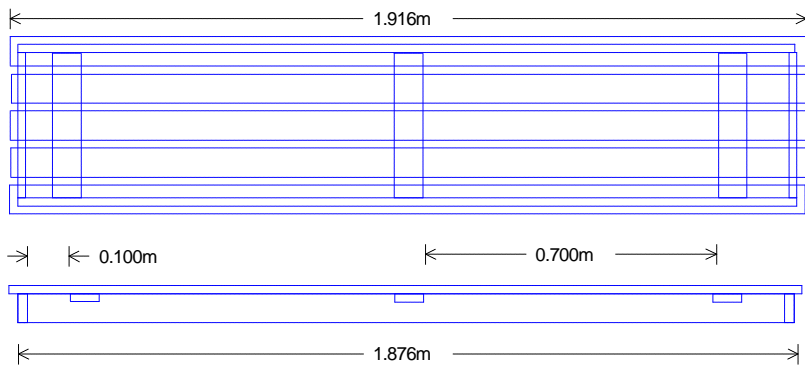
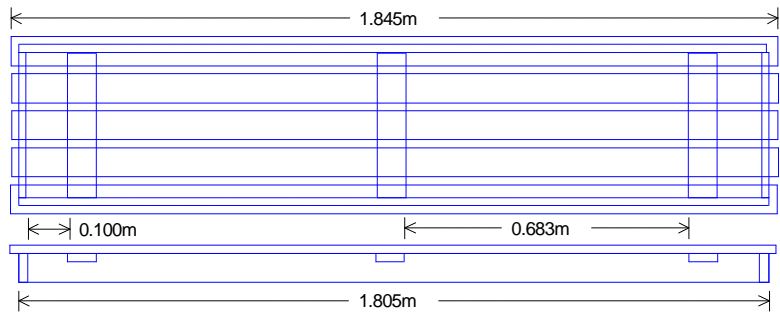
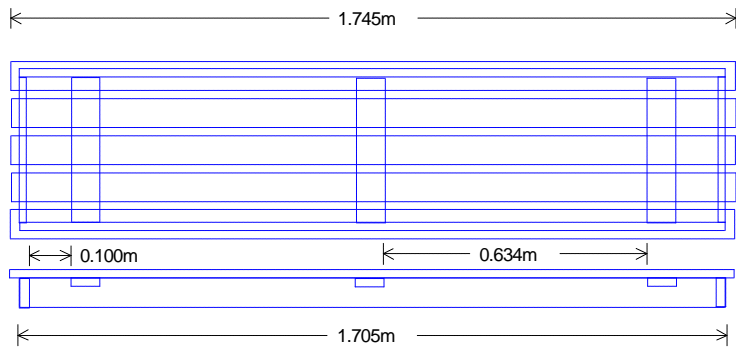
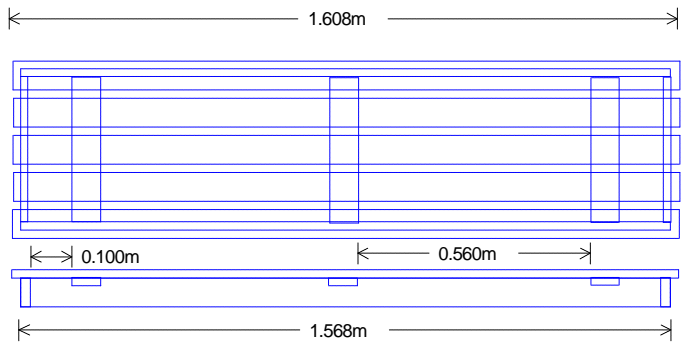

Assembly Procedure for Sauna Benches.



Refer to the line drawings below and on the inside face of the side rails mark the positions for the end rails and cross rails.



Using the brackets mark the hole positions for the fixing screws.



Using a 3 mm drill bit drill the holes to a depth of approximately 12 mm.



Fix the brackets to the side rails using the 20 mm screws.

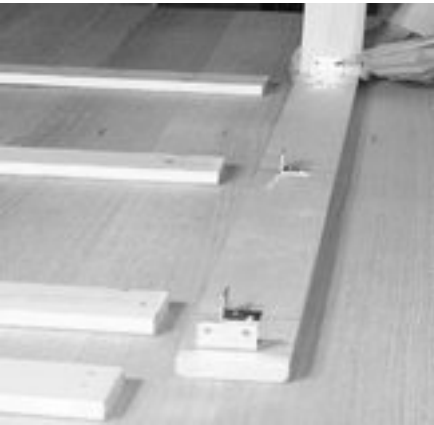

Loosely assemble the end rails and cross rails and use the brackets to mark the positions for the screw holes.



Fix the side rails to the end rails and cross rails through the brackets using the 20 mm screws.



Position the bench slats face side down using 19 mm spacing between slats. Ensure the slats are square.



Place the assembled frame onto the slats and centralise so that the slats overhang the frame by approximately 20 mm all the way around. Mark out the position for screw holes that will locate 2 screws at each intersection of the cross rails and the slats.



Fasten together using the 32 mm screws.



Fix brackets between the end rails and the slats using the same procedure as before ó mark the hole positions, drill the holes and then screw the brackets into place.



Lightly sand over and the bench assembly is complete.

Step 11.

Installation of benches; locate the overhanging section of bench onto the supports as per drill 2 x 3.5 mm holes into the underneath section of the end rails of the bench and fix using 2 x 3.5 x 40 mm screws into the support rails.

For benches over 1300 mm centre supports are provided, fit the support from underneath the bench locating the top rail to the centre cross rail and screw into place using 2 x 4 x 40 mm screws through 3.5 mm holes.



(P11)





Lower Bench Centre Support

Upper Bench Centre Support

Step 12.

Fitting the glass door we recommend this step is carried out after all the internal fittings have been installed.

Open the hinges and slide onto the support bases, fasten and adjust using the screws of the fitting as detailed opposite.



(P12)

Right hand screw = to release hinge and door from frame also allows door to move in and out from frame.

Left hand screw = Move door left to right

Middle adjuster = to move door up and down

To release hinge and door from frame also allows door to move in and out from frame.

Step 13. Affix outer trims.

Affix fascia corner blocks (item 11). Fix in place allowing the block to overhang the side of the cabin approx 8mm and flush with the top of the cabin fix using 25mm pins and glue.

Affix fascia (Item 10 6 9 x 32). Use two pieces of item 10 to the front of the cabin and two to each side (where accessible) fix using 25mm pins.

Affix skirting (Item 10 9 x 32). Use one piece all round cabin 6 beneath door frame use a 9mm packer beneath door frame as detailed in step 10.

Affix vertical joint overlaps (Item 9 x 32). Fix using 25mm pins. Spacing as detailed in item 10. Note corner detail shown opposite (i.e. 3 pieces to a front corner, one to rear side corner).



(P13)

Exhaust vent trim (kit)

Contents.

Top and bottom slider rail (9 x 32 + rebate)	2 off at 200mm
Side slider rail (9 x 32 + rebate)	2 off at 57mm
Vent sliders 3.5mm ply	1 off at 105 x 70

Assemble onto vent panel using 25mm pins (P14).



(P14)

To reduce size of cabin. (All models).

IMPORTANT NOTES (SAFETY CRITICAL).

At all times the clearance distances around the heater must be complied with.

The cabin capacity (M^3) must be within heater specification. The cabin door must always open outwards.

To reduce length or width of cabin.

Mark out on the panel (s) the portion to be cut off and cut thro using a saw. (P15).

If metal fixing is hit, use a flexback hacksaw blade in a pad saw to cut fixing. If using a circular saw

use a TCT blade and proceed slowly.

Remove framework (2 x 32) from discarded panel, strip off claddings etc. place 32 x 32 frame against remaining panel and mark off position of cross braces (P16). Cut framework to marked lines and push back into panel to be flush and pin in place through outer claddings (P17).

Safety Note.

The panels are constructed using metal fastenings and contain fibreglass/rockwool insulation, safety goggles and dust mask must be worn if using power tools.

Roof .

Cut roof panel as if for side panel, if reducing length of panel use same sequence, measure, mark, cut, replace framework and pin in place. (P18).

Important note.

Make sure the recut frame work is a good fit between cross braces. As the panel carries the load of the roof. If you are reducing both length and width of the cabin, ensure the modified ends of panels are never adjacent to each other.

To reduce the height of cabin. First check heater clearances then proceed as for side and roof panels.

If you are in any doubt regarding clearances please ring our Technical Department.



(P15)



(P16)



(P17)



(P18)

Benches.

Reduce side slats by same amount as wall panels, remove any part of the fillet blocks that impede the fixing of the notched cross rails and refix vertical blocks for end rail fixing ó screw and glue ALL joints.

Backrests.

Contents. Dependant on cabin type (the number and size will be shown on your parts list)



Two slat Backrests (Celebration) will use 69 x 18 x 125 fixing pads.

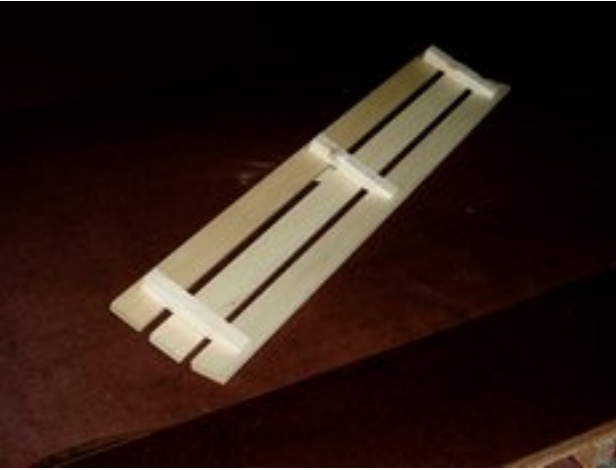

Three slat Backrests (Deluxe) will use 32 x 32 x 215 angled fixing pad.

Assembly ó Position fixing pad approximately 70mm from end of slat fix using 32 x 3.5 screws (x2) in from rear through pad into each slat, leave a 18mm gap between slats. Drill and countersink a 3.5mm hole through pad in the gap between slats, to fix to cabin wall. Fix into cabin using 3.5 x 32 screws. Locate approx 300mm above benches.



Floor mats ó Factory assembled size 500mm x 500mm



Headrest. - Factory assembled

Heater & Heater Guard

Refer to the separate instructions supplied with the Heater for installing the heater observe all clearance distances and then fix the wooden heater guard in place around the heater by drilling 3.5 mm holes screwing through each of the 19 x19 uprights and fastening to adjacent walls using 2 x 4 x 40 mm screws into each wall.

It is important that the top rail of the guard is set at least 25 mm below the rim of the heater such that it does not receive heat radiation directly from the heater rocks.



Locating accessories.

Thermometer.

Inside cabin approx 200mm from ceiling on opposite wall from stove.

Sand timer.

Inside cabin ó on any wall but away from stove.

Wall light ó inside cabin.

Lamp & Shade ó Centre wall above bench. Approx 100mm from ceiling.

Low Voltage Lights (deluxe model)

Holes can be drilled where applicable (not factory pre-drilled)

Instruction card ó outside cabin.

Sauna Clock (deluxe model) ó outside cabin

Sauna Heater ó inside cabin

See layout drawing of cabin

Please note sauna heaters do not operate from a 3 pin plug, they require hard wiring using high temperature silicon rubber cable to BSEN 6141. (not included)

Electricians can normally obtain this from their supplier but in case of difficulty please contact our technical department for further advice. The length you will require depends upon the distance between where you locate your control box and the heater.

Control Box for Heater ó outside cabin

Please note sauna heaters do not operate from a 3 pin plug, they require hard wiring using high temperature silicon rubber cable to BSEN 6141. (not included)

Electricians can normally obtain this from their supplier but in case of difficulty please contact our technical department for further advice.

The length you will require depends upon the distance between where you locate your control box and the heater.

If you encounter any difficulty with this assembly procedure or think we could have explained anything more clearly we would welcome your comments; please ☎ 01902 871127 technical help line.